

Design A for the power lower than 6,3 kVA

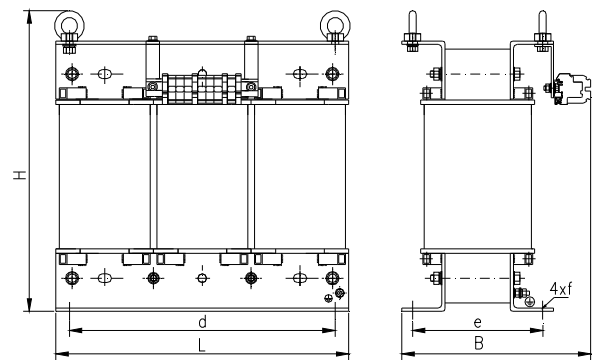

Design B for the power 6,3 kVA and more

Technical data:

Design	Safety isolating transformers produced in accordance with requirements of EN/IEC 61558-2-6
Insulation class	B(130°C) - standard up to 5 kVA, F(155°C) - standard above 5 kVA
Climatic class /environmental	C1/E0 - land design C2/E1 - maritime and mining design
Ambient temperature	40°C - land design 45°C - maritime and mining design
Protection degree	IP 00
Protection class	I
Frequency	50/60 Hz
Vector group	Dyn5 - standard
Primary voltage	up to 1000 V
Secondary voltage	up to 50 V
Terminals	screw terminal blocks with the cross section from from 4 mm ² up to 150 mm ² or copper bus bars
Fastening	by means of angles

Three-phase safety isolating transformers are assigned for supplying electric devices with safe voltage.

In standard design, the transformers are adjusted to fastening by means of screwed angles.

The windings terminals may be placed on one side only, or on both sides of a transformer. Upon request, the transformers may be assembled in enclosures with the protection degree of IP 23, IP 44 and IP 54.

Technical data of three-phase safety isolating transformers ET3o **

Type	Power [kVA]	L [mm]	B [mm]	H [mm]	d [mm]	e [mm]	f [mm]	Weight [kg]	Design
ET3o_* - 0,05	0,05	100	60	122	81	41	5 x 8	1,4	A
ET3o_* - 0,15	0,15	125	71	140	100	55	5 x 8	2,6	A
ET3o_* - 0,3	0,3	155	91	156	130	71	8 x 12	5,1	A
ET3o_* - 0,5	0,5	195	102	185	173	82	8 x 11	7,5	A
ET3o_* - 0,63	0,63	195	112	185	173	92	8 x 11	9,5	A
ET3o_* - 0,8	0,8	195	112	185	173	92	8 x 11	10,5	A
ET3o_* - 1,0	1,0	210	105	200	173	85	8 x 11	12	A
ET3o_* - 1,5	1,5	240	131	226	198	105	11 x 15	16	A
ET3o_* - 2,0	2,0	240	146	226	198	120	11 x 15	22	A
ET3o_* - 2,5	2,5	261	140	239	198	114	11 x 15	26	A
ET3o_* - 3,0	3,0	300	152	274	240	122	11 x 15	30	A
ET3o_* - 4,0	4,0	300	165	274	240	135	11 x 15	38	A
ET3o_* - 5,0	5,0	300	192	274	240	160	11 x 15	49	A
ET3o_* - 6,3	6,3	360	230	365	310	125	11 x 15	47	B
ET3o_* - 7,5	7,5	360	237	365	310	132	11 x 15	54	B
ET3o_* - 8,0	8,0	360	247	365	310	142	11 x 15	60	B
ET3o_* - 10,0	10,0	360	270	365	310	162	11 x 15	71	B
ET3o_* - 12,5	12,5	420	255	425	370	158	11 x 15	82	B
ET3o_* - 15,0	15,0	420	265	425	370	168	11 x 15	91	B
ET3o_* - 16,0	16,0	420	265	425	370	168	11 x 15	92	B

*) - for transformer design with climatic/environmental class C2/E1 (maritime design W/3 or tropical design T/3) the letter "M" or "G" ought to be added depending on final application

**) - this table was prepared basing on the technical specification for transformer with voltage ratio 400/24 operating under normal conditions. For other conditions and data the values may change

Note:

Manufacturer reserves the right to make changes resulting from the continuous development of products offered. If requested in advance, it is possible to manufacture transformer in other version.